

C-Band VSAT Block Up Converters

Configurations

10W BUC,

70dB gain
11 lbs. (5.0 kg)

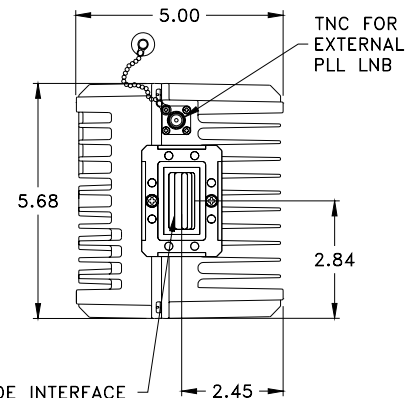
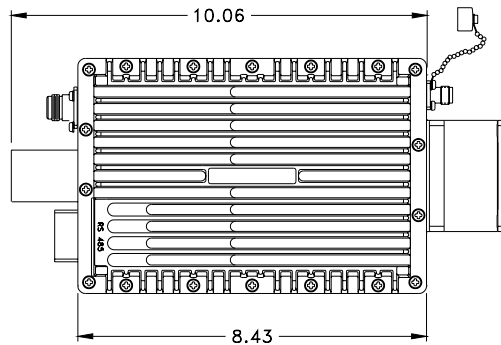
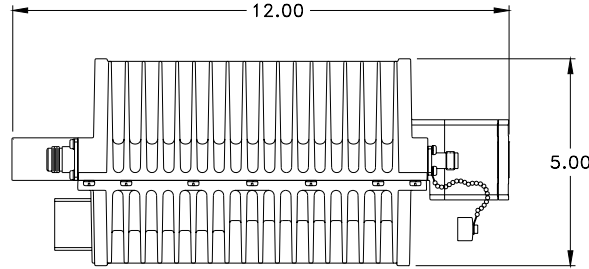
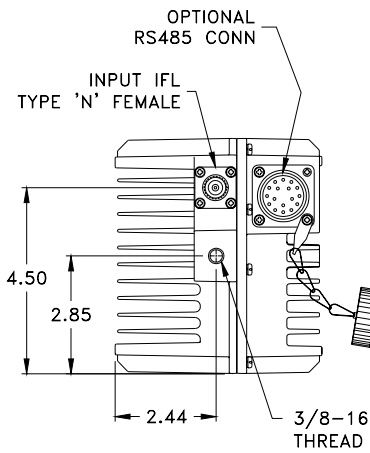

WR-137 WAVEGUIDE INTERFACE
(10-32 MTG HARDWARE)
GASKET REQUIRED AND SUPPLIED

20W BUC

Same enclosure
as 10W BUC
with cooling fan attached

73 dB gain
11 lbs. (5.0 kg)

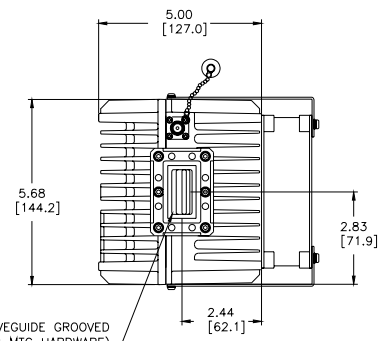
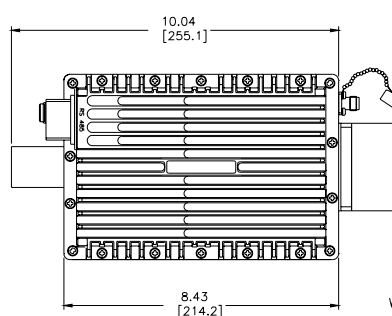
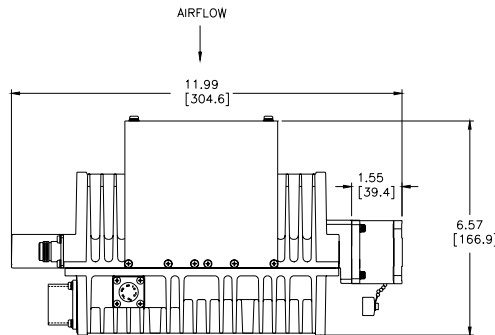
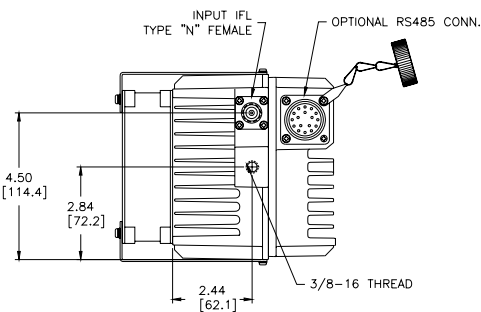

C-Band VSAT Block Up Converters



Electrical Parameters

PARAMETER	NOTES	LIMITS	UNITS
Output Frequency Range	4.90 GHz Local Oscillator	5.850 to 6.425	GHz
Input Frequency Range		950 to 1525	MHz
Input level range, without damage	-30 dBm for P _{1dB}	-55 to 0	dBm
Reference signal frequency	External to BUC	10	MHz
Reference signal level		-3 to +10	dBm
Output Power (Guaranteed minimum P _{1dB})	10W 20W	P _{1dB} , minimum 40 43	dBm dBm
Overall Gain (-0, +4dB) (inclusive of temperature range)	10W 20W	70 73	dB dB
Gain Stability	at constant temperature	± 0.5	dB
Gain flatness over 575 MHz	inclusive of temperature range	± 4	dB
Gain flatness over any 5 MHz	inclusive of temperature range	± 0.25	dB
Intermodulation Distortion	3dB back off relative to P _{1dB}	-26	dBc
AM/PM Conversion	(@ rated P _{1dB})	3.5	°/dB
Group Delay	Over any 5 MHz	<10	ns
Transmit Interrupt Isolation	TX inhibit	>60	dB
Spurious in band		-50	dBc
Spurious out of band	As defined by ETSI mask	f _c ±0.5 GHz	-
Receive band noise	In 100 KHz band	< -100	dBm
BUC Phase Noise	Double sideband Integrated	2.8	degrees rms
	10 Hz 100 Hz 1 KHz 10 KHz 100 KHz 1 MHz	-65 -73 -80 -85 -105 -120	dBc/Hz dBc/Hz dBc/Hz dBc/Hz dBc/Hz dBc/Hz
External Reference Phase Noise	10 Hz 100 Hz 1 KHz 10 KHz	-105 -134 -144 -154	dBc/Hz dBc/Hz dBc/Hz dBc/Hz
Noise Figure		< 20	dB
Output Return Loss	In WR 137 waveguide	> 14	dB
L Band input impedance		50	ohms
Input Return Loss		> 12	dB

Environmental

Operating Temperature		-40 to +55	C
Survival Temperature		-50 to +70	C
Humidity	condensing	100	%
Rain, Snow, Ice		Operational	-

C-Band VSAT Block Up Converters



Interfaces

RF Output Connector	Waveguide Output	WR 137	CPR-137 G
L Band Input Connector	IF, DC, 10 MHz, FSK Input	Type N	female
M & C Connector	Alternate DC Input, RS-485 Serial I/O	MS3102E20-29P	Plug
	Optional Form C Summary Alarm and SPI link for Booster Amplifier	Pin Out	
	Serial Communication	C	RS-485 (-)
	Serial Communication	D	RS-485 (+)
	Ground	J	GND
	Alternate DC Input	K	+ Vin
	Alternate DC Input	L	+ Vin
	Ground	M	GND
	Summary Alarm Contacts	P	Form A – Open on Fault
	Summary Alarm Contacts	N	Form A – Common
Reserved for Booster Communication	B	MISO	
Reserved for Booster Communication	E	HPA PIC_SEL	
Reserved for Booster Communication	F	PIC_CLK	
Reserved for Booster Communication	G	SS	
Reserved for Booster Communication	R	MOSI	
Reserved for Booster Communication	S	PIC_SEL	

Monitor and Control

RF Output Power	Measurement range	$P_{1dB} - 20$	dB
	accuracy	± 1	dB
Alarm	Phase Lock Oscillator	Loss of Lock	-
Gain Adjust	Available in BUC only, when used with Booster amplifier gain is fixed	15	dB
Temperature	Internal Temperature	-40 to +50	C
Transmit On/Off	Amplifier mute function	-	-
Status Request		-	-
Address Set	Used in RS-485 network	-	-

Specifications are subject to change.

Monitor and Control

The Block Up Converter can communicate with a host computer by means of a 2-wire RS-485 interface or 650 KHz Frequency Shift Keying (FSK) interface. The 2-wire RS-485 interface is available at the circular M&C connector, MS3102E20-29P. The FSK input must be diplexed onto the coaxial L-Band input via the connector. The FSK will always take priority over the RS-485. Therefore if the BUC receives commands from both ports, only the FSK signal will reach the internal micro-controller. The 2-wire RS-485 port includes an internal 120 ohm terminating resistor.

The RS-485 communication operates at a fixed Baud rate of 9600. The FSK signal operates with a deviation of ± 60 KHz. For a complete description of the communication protocol, request Paradise Datacom document 201410.

C-Band VSAT Block Up Converters

DC Power Options for Block Up Converters

The following table shows the DC bias current and BUC configuration for the various power levels.

Block Up Converter	Available DC Power Options			DC Current		Notes
	T	F (24 V) (22 - 32)	P (48 V) (36 - 60)	@ 24 V (22 - 32)	@ 48 V (36 - 60)	
10W C-Band		●	●	5.0A	2.5A	Figure 1 or 2
20W C-Band		●	●	6.0A	3.0A	Figure 1 or 2

Figure 1: IF powered through external Bias Tee

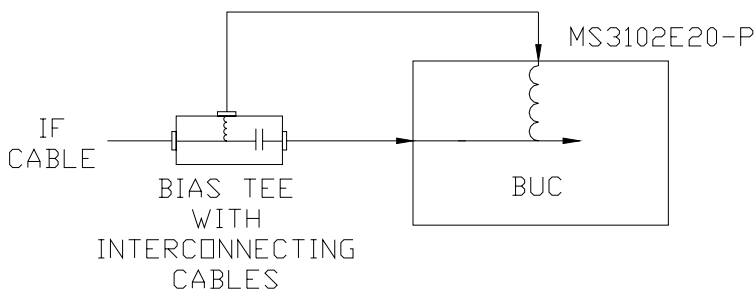

3	1	C	-	1	0	A	X	X	3	P	X	X
3	1	C	-	2	0	A	X	X	3	P	X	X



External Bias Tee and cables will be added to sales order.

Figure 2: DC blocked to IF port (Options “F” and “P”)

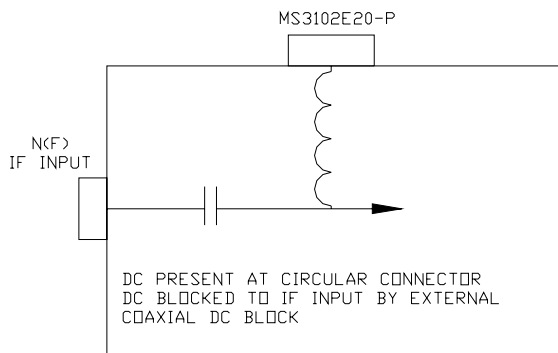

3	1	C	-	1	0	A	X	X	3	F	X	X
3	1	C	-	1	0	A	X	X	3	P	X	X
3	1	C	-	2	0	A	X	X	3	F	X	X
3	1	C	-	2	0	A	X	X	3	P	X	X

C-Band VSAT Block Up Converters



Configurator: Block Up Converters

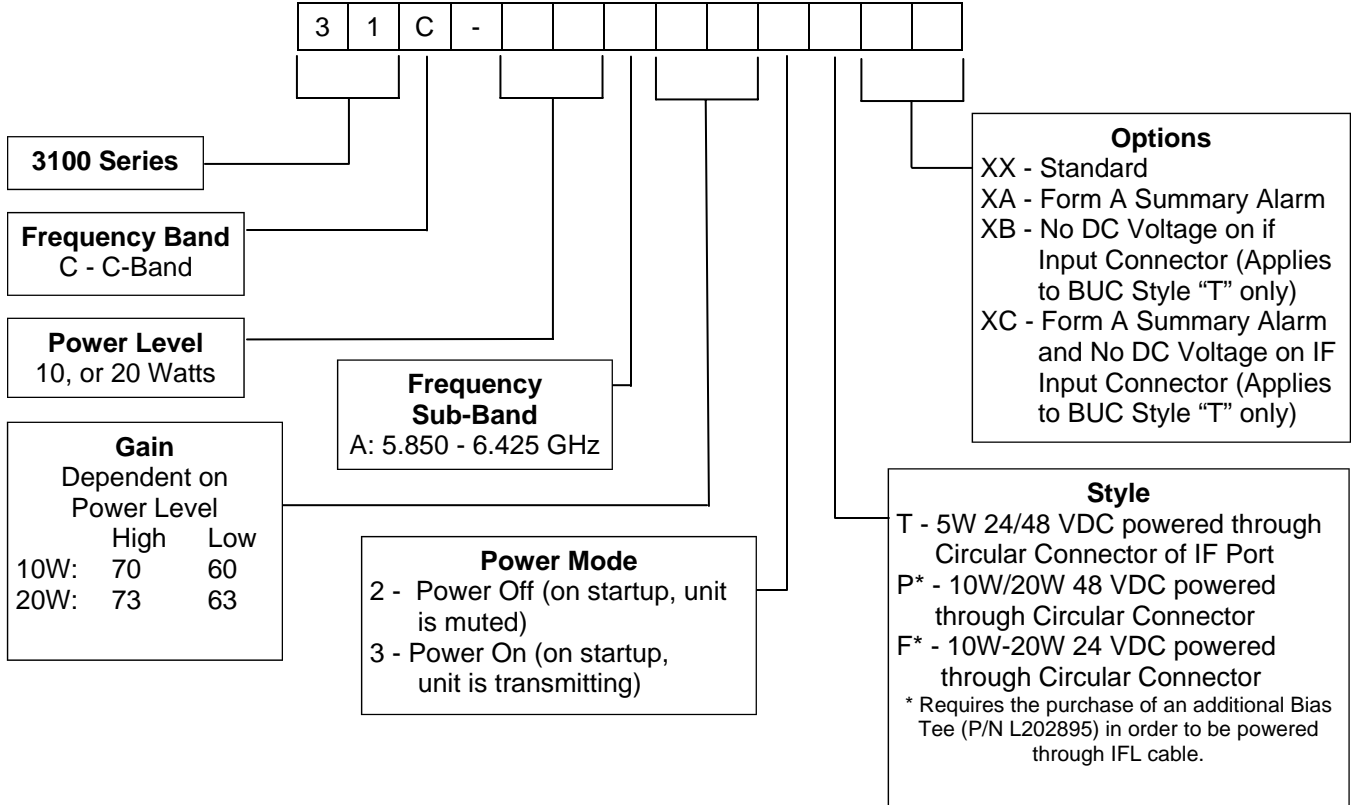

C-Band VSAT Block Up Converters



Configurator: Redundant BUC Assemblies

